

# PREMIUM K. D. 16-PERSON STOCK LOCKER ASSEMBLY INSTRUCTIONS

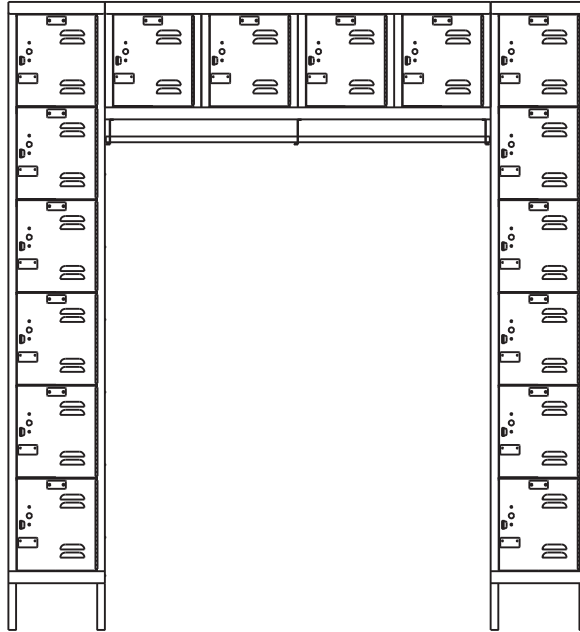

## General Instructions

1. Check material received against the packing list. First check the number of packages received and then check the contents of each package.
2. Check material received for damage. If damage has occurred, secure a "damage notation" from the carrier.
3. Identify each part as it is unpacked and put like parts together as close as possible to the working area in which they are to be assembled.
4. Be careful to use the correct hardware as specified in the assembly instructions.
5. Items with suffix (xx) are available options.

## CAUTION

IN THE INTEREST OF SAFETY, ALL LOCKERS MUST BE SECURELY ANCHORED TO THE FLOOR AND/OR WALL.  
FOR SAFETY, HANDLE ALL COMPONENTS CAREFULLY AND WEAR WORK-GLOVES WHEN ASSEMBLING LOCKERS.

INSTALL ALL UNITS PLUMB AND TIGHTEN ALL HARDWARE SECURELY.

RETAIN INSTRUCTIONS FOR FUTURE REFERENCE.



Sold By **SchoolLockers.com**

877.952.0151

# PREMIUM K. D. 16-PERSON STOCK LOCKER ASSEMBLY INSTRUCTIONS

## PACKAGE CONTENTS

REF. NO.	DESCRIPTION	PART NO.	QTY.
①	REAR PANEL	KR1272	2
②	RIGHT/LEFT SIDE PANEL	KP1872-16P	4
③	TOP/BOTTOM SHELF	KS1218	4
④	INTERMEDIATE SHELF	KH1218	10
⑤	DOOR FRAME ASSEMBLY	KDF1278-6	2
× ⑥	DOOR	KD1272-6LV	16
⑦	BOX DOOR LATCH PULL	KBLP100	16
⑧	NUMBER PLATE	NPH	16
⑨	NUMBER PLATE RIVET	RV101	32
×× ⑩	STRIKE PLATE	××SP100	××16
⑪	REAR LEG	KLG	4
⑫	3/8" SLOTLESS BOLT	MBT200	243
⑬	HEX NUT	N201	211
⑭	HI-DOME CAP NUT	N110	32
× ⑮	PIANO HINGE	PH11	16
⑯	COAT ROD BRACKETS	THR 200	3
⑰	COAT ROD	KCR48	1
⑱	DOOR FRAME ASSEMBLY	KF4812-16A	1
⑲	CENTER REAR PANEL	KR16CP	1
⑳	CENTER BOTTOM	KP16CB18	1
㉑	CENTER TOP	KP16CT18	1
㉒	CENTER SIDE PANEL	KP16CS18	3
× ㉓	RIVET (HINGE)	RV102	32

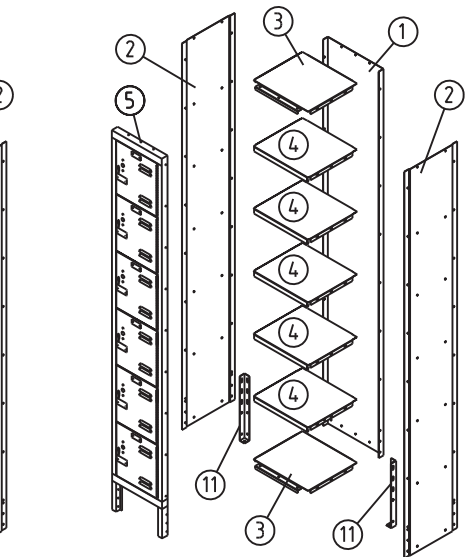
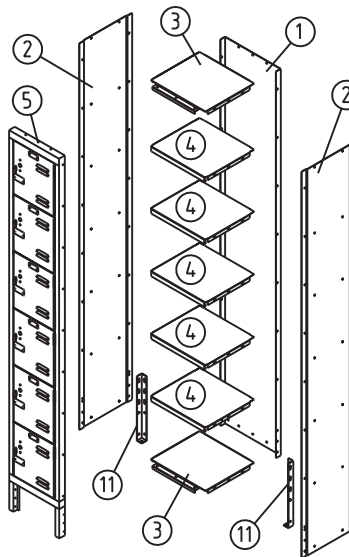
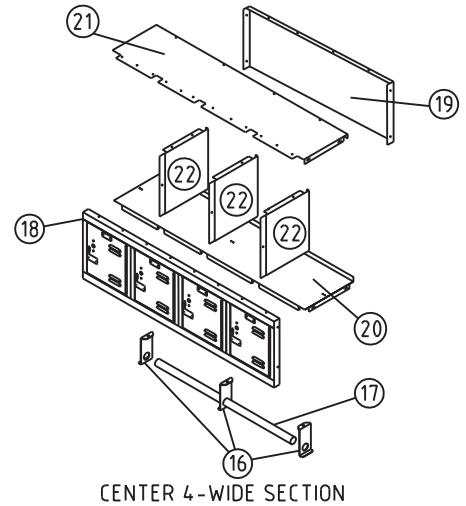
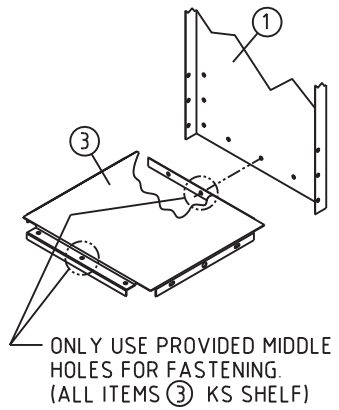

### NOTE:

FOR OPTIONAL INDIVIDUAL SLOPE TOPS,  
SEE SUPPLEMENTAL INSTRUCTION SHEET NO. ASY-H-KIST-A

FOR OPTIONAL 6" HIGH CLOSED METAL BASE,  
SEE SUPPLEMENTAL INSTRUCTION SHEET NO. ASY-H-KIST-B

× SHIPS PRE-HUNG IN FRAME ASSEMBLY.

×× STRIKE PLATES ARE OPTIONAL - INCLUDES TWO RIVETS ⑨.

**TOOLS REQUIRED: 3/8" NUT  
DRIVER (3/8" SOCKET MAY BE  
SUBSTITUTED)**

## TWO-YEAR WARRANTY

HALLOWELL KD LOCKERS ARE COVERED AGAINST ALL DEFECTS IN MATERIALS AND WORKMANSHIP EXCLUDING FINISH, DAMAGE RESULTING FROM DELIBERATE DESTRUCTION AND VANDALISM FOR A PERIOD OF TWO YEARS.

Sold By  
**SchoolLockers.com**



877.952.0151

# PREMIUM K.D. 16-PERSON STOCK LOCKER ASSEMBLY INSTRUCTIONS

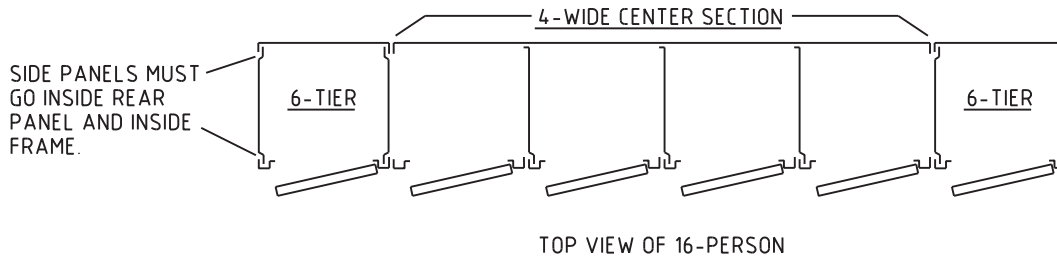

## 6-TIER LEFT AND RIGHT TOWER SECTIONS

### FINGER TIGHTEN ONLY UNTIL FINAL ASSEMBLY

#### STEP 1

LAY REAR KR ① DOWN

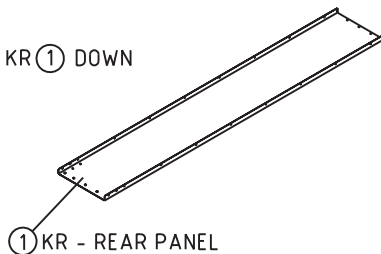

#### STEP 2

BOLT KP ② SIDE PANELS TO KR ① REAR PANELS.

SIDE PANELS ② FIT TO INSIDE OF REAR PANEL FLANGES.

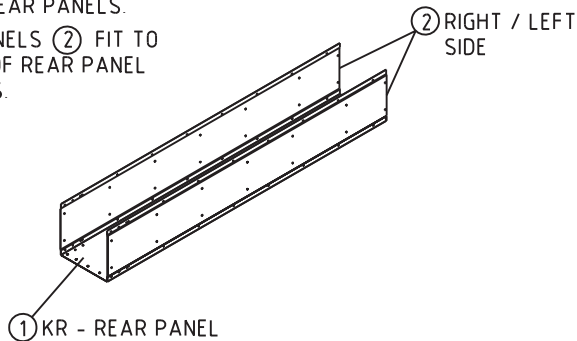

#### STEP 3

INSTALL KS ③ SHELVES AND KH ④ SHELVES TO UNIT.

NOTE: LEAVE TOP SHELF ③ AND TOP HAT SHELF ④ OF 6-TIER UNFASTENED AS SHOWN UNTIL CENTER SECTION FRAME IS BOLTED IN PLACE.

INSTALL TWO KLG ⑪ REAR LEGS TO INSIDE OF SIDE ② AND REAR PANEL ① BY SLIDING INTO PLACE FROM BOTTOM.

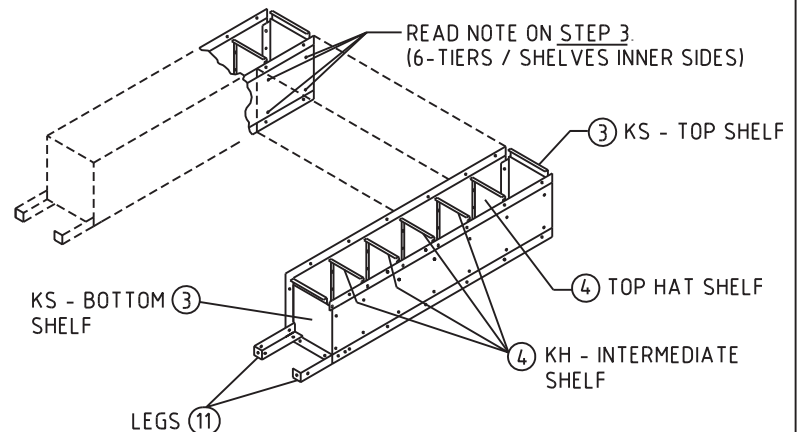

#### STEP 4

BOLT DOOR AND FRAME ⑤ ASSEMBLIES TO KS ③ SHELVES AND KP ② SIDE PANELS. STAND UNIT UP AND ALIGN LOCKER TOPS EVENLY. TIGHTEN ALL BOLTS AND NUTS.

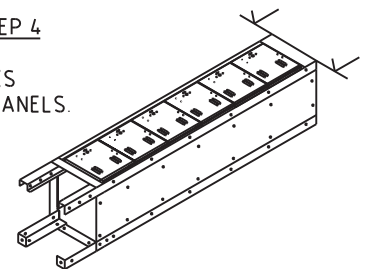

HALLOWELL MAKES EVERY EFFORT TO ENSURE THAT ALL UNITS SHIP COMPLETE. HOWEVER, SHOULD YOUR UNIT CONTAIN MISSING OR DAMAGED PARTS, REPLACEMENTS MAY BE OBTAINED FROM HALLOWELL. TO OBTAIN PARTS, FOLLOW THESE INSTRUCTIONS.

PLEASE PROVIDE THE FOLLOW INFORMATION:

MODEL NUMBER

PURCHASE DATE

DESCRIPTION OF PART(S) NEEDED & PART NUMBER(S) AS SHOWN IN PARTS LIST

COMPANY NAME & CONTACT PERSON

COLOR

WHERE THE PRODUCT WAS PURCHASED FROM

IF REQUESTING PARTS BY TELEPHONE, ASK FOR CUSTOMER SERVICE & PROVIDE THE ABOVE INFORMATION.

Sold By

**SchoolLockers.com**



877.952.0151

# PREMIUM K.D. 16-PERSON STOCK LOCKER ASSEMBLY INSTRUCTIONS

## CENTER SECTION

### STEP 5

BOLT KP16CT (21) CENTER TOP TO KP16CS (22) CENTER PANEL.

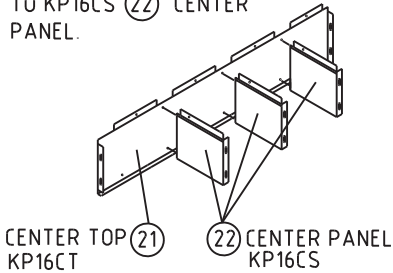

### STEP 6

BOLT (21) TOP AND (22) CENTER PANEL TO KR16CP (19) CENTER REAR PANEL.

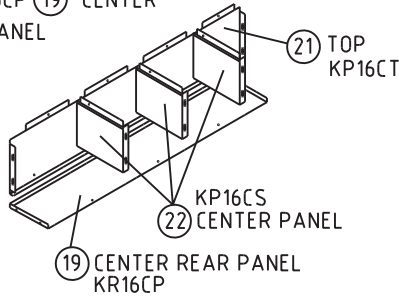

### STEP 7

BOLT KP16CB (20) CENTER BOTTOM TO (19) CENTER REAR AND (22) CENTER PANEL.

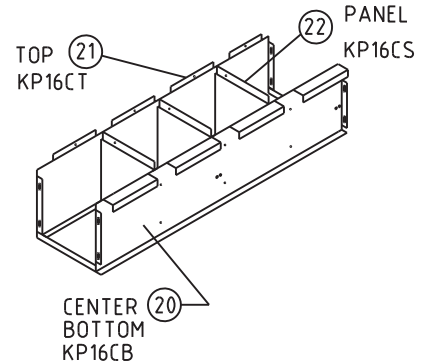

### STEP 8

BOLT KF4812-16A (18) DOOR FRAME ASSEMBLY TO CENTER ASSEMBLY

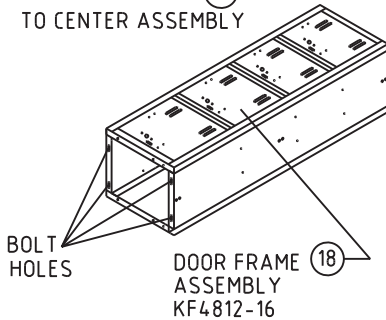

### STEP 9

WITH REAR OF CENTER SECTION ON A FLAT SURFACE, ATTACH TO LEFT AND RIGHT 6-TIER LOCKERS, TOP SHELVES AND TOP HAT SHELVES INNER SIDES, USING 10-24 x 1/2" BOLTS THRU HOLES SHOWN ON STEP 3 AND STEP 8.

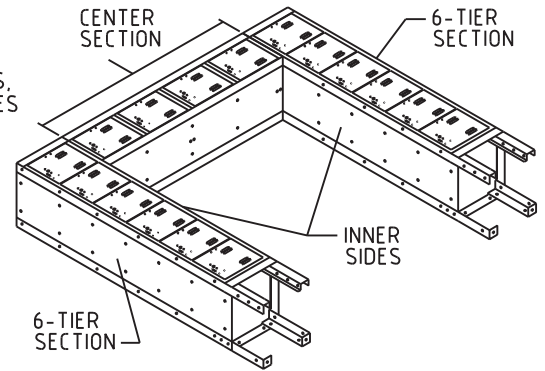

### STEP 10

BRACKETS TO BE BOLTED TO UNDERSIDE OF CENTER UNIT WITH COAT ROD IN BETWEEN.

- (16) COAT ROD BRACKET TRH 200
- (17) COAT ROD KCR4.8

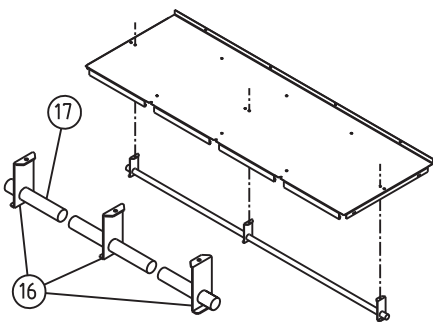

### STEP 11

STAND LOCKER SECTION

### STEP 12

- (12) SLOTLESS BOLT
- (14) HI-DOME CAP NUT
- (7) BOX DOOR LATCH
- (15) PIANO HINGE
- (10) STRIKE PLATE
- (9) NUMBER PLATE RIVET

ASSEMBLY OF STRIKE PLATE & LATCH PULL

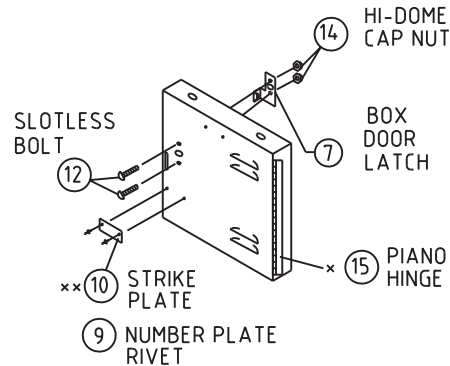

### STEP 13

- (8) NUMBER PLATE
- (9) NUMBER PLATE RIVET
- (X) 6 DOOR

ASSEMBLY OF NUMBER PLATE

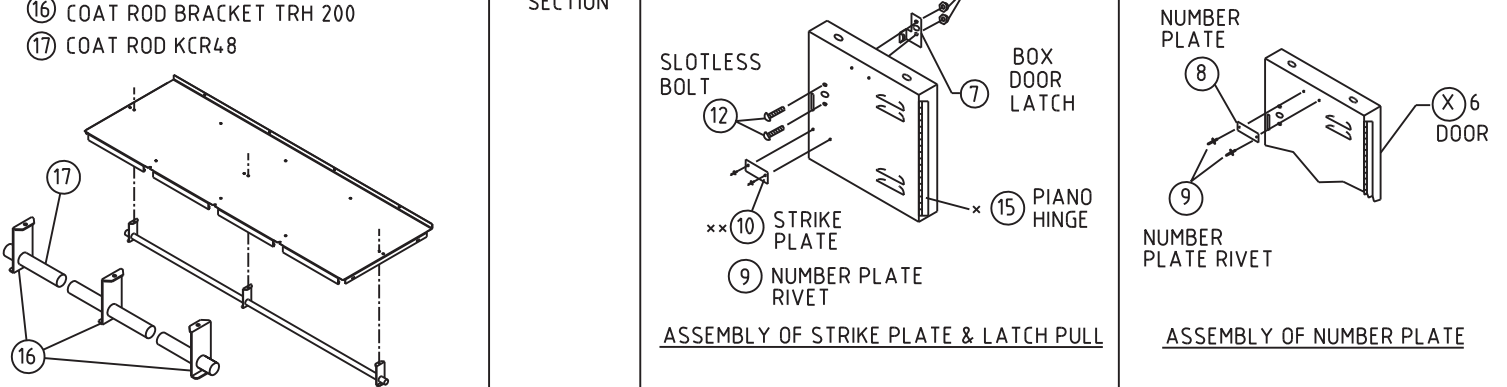

### HARDWARE USED FOR MAIN LOCKER ASSEMBLY



10 - 24 x 3/8"

MBT200 SLOTLESS BOLT (12)



N201 HEX NUT (13)

TIGHTEN NUT WITH A NUT DRIVER OR WRENCH (SCREW IS TAMPER RESISTANT).

Sold By  
**SchoolLockers.com**



877.952.0151