

PREMIUM K.D. WARDROBE STOCK LOCKER ASSEMBLY INSTRUCTIONS

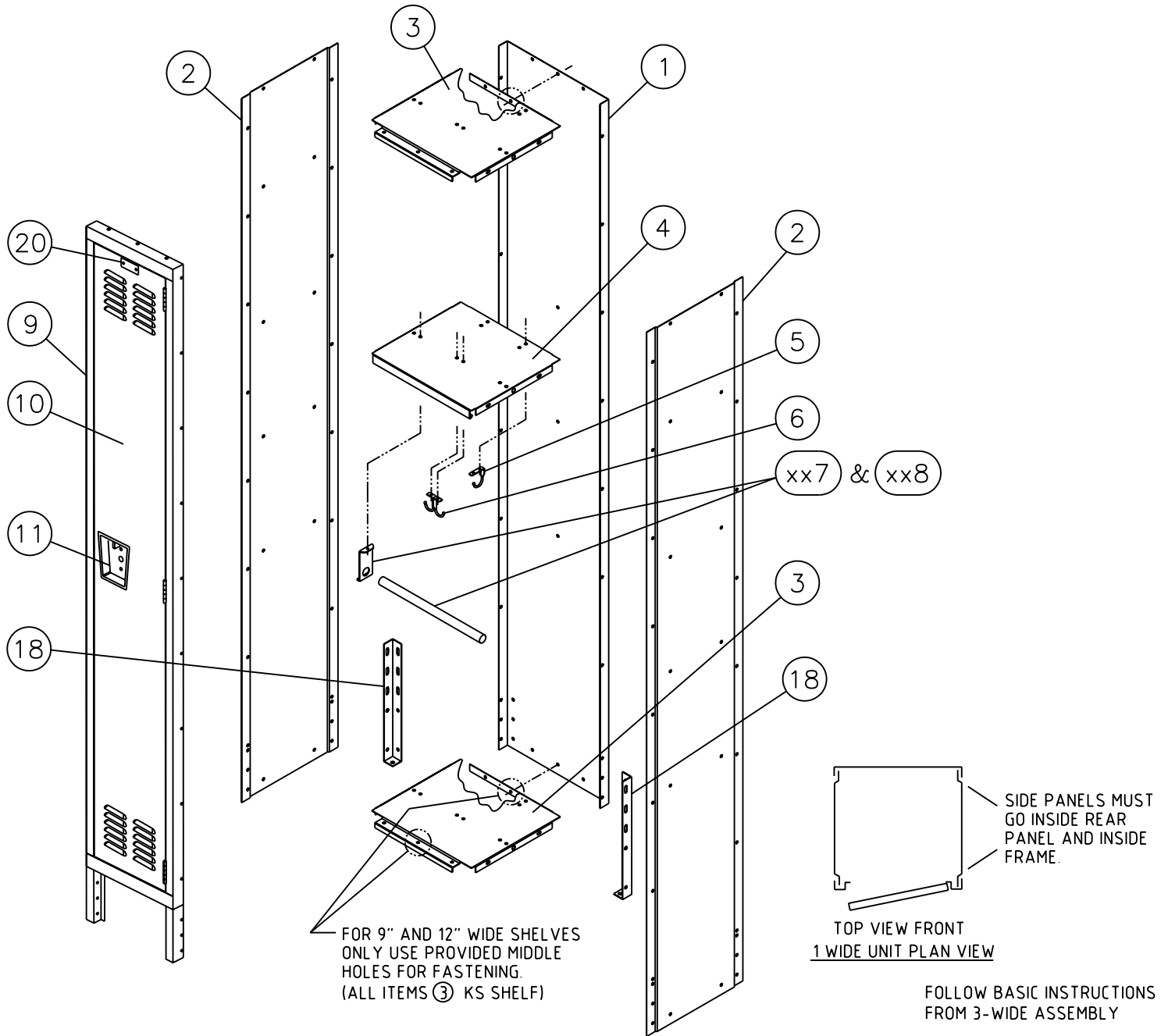

COAT ROD (KCR_{ww}) & COAT ROD BRACKETS (TRH 200) ARE OPTIONAL.

HALLOWELL MAKES EVERY EFFORT TO ENSURE THAT ALL UNITS SHIP COMPLETE; HOWEVER, SHOULD YOUR UNIT CONTAIN MISSING OR DAMAGED PARTS, REPLACEMENTS MAY BE OBTAINED FROM HALLOWELL. TO OBTAIN PARTS, FOLLOW THESE INSTRUCTIONS.

PLEASE PROVIDE THE FOLLOW INFORMATION:

MODEL NUMBER

DESCRIPTION OF PART(S) NEEDED & PART NUMBER(S) AS SHOWN IN PARTS LIST

COLOR

PURCHASE DATE

COMPANY NAME & CONTACT PERSON

WHERE THE PRODUCT WAS PURCHASED FROM

IF REQUESTING PARTS BY TELEPHONE, ASK FOR CUSTOMER SERVICE & PROVIDE THE ABOVE INFORMATION.

Sold By



