

FIGURE 1.1

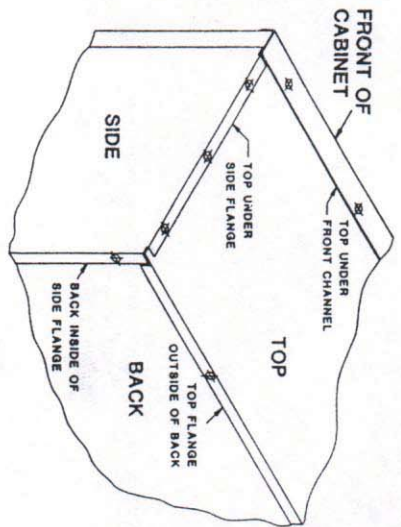

FIGURE 1.2

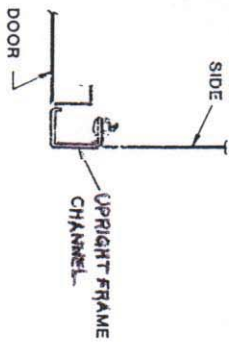

FIGURE 1.3

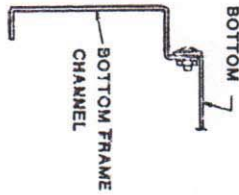

FIGURE 1.4

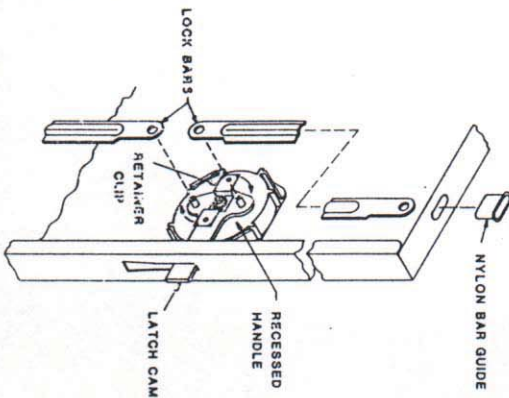

FIGURE 2

- STEP 1. BODY ASSEMBLY (FIG. 1.1)**
- 1.1 LAY BACK DOWN FLAT. TAKE A SIDE AND PLACE THE FLANGE ON THE SIDE UNDER THE BACK. (FIG. 1.2) NOTE THAT BOTH SIDES ARE THE SAME AND CAN BE USED ON EITHER SIDE. MAKE SURE SHELF ADJUSTMENT TABS ARE FACING TOWARDS TOP. LINE UP HOLES AND BOLT PARTS TOGETHER WITH NUTS ON INSIDE OF CABINET. HAND TIGHTEN ONLY.
 - 1.2 POSITION THE TOP SO THE REAR FLANGE IS UNDER THE BACK AND THE TOP FLANGE OF THE SIDE IS OUTSIDE OF THE TOP (FIG. 1.2) BOLT PARTS TOGETHER. HAND TIGHTEN ONLY.
 - 1.3 TAKE THE OTHER SIDE AND REPEAT STEP 1.1 IN ADDITION TO BOLTING SIDE TO TOP.
 - 1.4 INSTALL THE BOTTOM INTO THE CABINET SO THE HOLES IN THE REAR FLANGE OF THE BOTTOM LINE UP WITH THE HOLES IN THE BACK. BOLT TOGETHER VERY LOOSELY ALIGNING THE BOTTOM TO LEAN TOWARDS THE TOP OF THE CABINET PROVIDING CLEARANCE FOR THE DOOR FRAME INSTALLATION.
 - 1.5 WITH THE DOOR AND FRAME LAYING FLAT, LOWER DOOR AND FRAME ON TO ASSEMBLED CABINET BODY MAKING SURE TOP OF FRAME IS ON THE OUTSIDE OF TOP. CAREFULLY OPEN RIGHT HAND DOOR AND HOLD UP TO PREVENT DAMAGE. LINE UP THE HOLES IN THE FRAME AND SIDE AND BOLT TOGETHER. (FIG. 1.3) HAND TIGHTEN ONLY.
 - 1.6 CAREFULLY OPEN LEFT HAND DOOR AND HOLD OPEN. LINE UP THE HOLES IN THE FRAME AND SIDE AND BOLT TOGETHER. HAND TIGHTEN ONLY.
 - 1.7 PUSH THE BOTTOM ON TO THE HOOKS OF THE SIDE ADJUSTMENT STRIPS AND OVER THE TOP FLANGE OF THE BOTTOM FRAME CHANNEL. LINE UP THE HOLES AND BOLT TOGETHER (FIG. 1.4)
 - 1.8 LINE UP THE HOLES IN THE TOP AND TOP FRAME CHANNEL AND BOLT TOGETHER.
 - 1.9 AT THIS POINT, TIGHTEN ALL NUTS, CLOSE DOORS AND CAREFULLY STAND CABINET UPRIGHT.

- STEP 2 LOCK ASSEMBLY (FIG. 2)**
- 2.1 INSTALL HANDLE ASSEMBLY INTO RIGHT HAND DOOR BY INSERTING THE LATCH CAM THROUGH LARGE HOLE AND INTO THE SLOT ON DOOR EDGE. SUPPORT THE INSIDE OF THE DOOR WITH OPPOSITE HAND AND PUSH HANDLE INTO LARGE HOLE UNTIL FULLY SEATED ASSURING THAT THE FOUR INTEGRAL LOCKING TABS ON HANDLE ARE FULLY ENGAGED ON DOOR.
 - 2.2 SNAP NYLON LOCK BAR GUIDES INTO THE TOP AND BOTTOM FLANGES OF THE RIGHT HAND DOOR.
 - 2.3 ROTATE RETAINER CLIP (EITHER DIRECTION) OFF OF THE PINS ON THE LATCH CAM. ASSEMBLE LOCK BARS INTO GUIDES AND ON TO PINS ASSURING THAT THE TOP LOCK BAR IS ON THE TOP PIN. ROTATE RETAINER CLIP UNTIL IT SNAPS OVER TIPS OF PINS.
 - 2.4 CHECK OPERATION OF LOCKING MECHANISM WHILE DOOR IS OPEN.

GENERAL INSTRUCTIONS

1. THESE ARE THE INSTRUCTIONS FOR THE PERSON WHO WILL ACTUALLY SUPERVISE OR DO THE ASSEMBLY. SEE THAT THEY GET THEM.
2. CHECK THE NUMBER OF PACKAGES RECEIVED AGAINST THE BILL OF LADING. IF ANY SHORTAGES, SECURE A "SHORTAGE NOTATION" FROM THE CARRIER AND FILE FOR CLAIM. CHECK MATERIAL RECEIVED FOR DAMAGE. IF ANY IS DAMAGED, SECURE A "DAMAGE NOTATION" FROM THE CARRIER AND FILE FOR CLAIM AGAINST CARRIER.
3. CHECK MATERIAL RECEIVED AGAINST YOUR COPY OR ORDER.
4. WHEN UNPACKING, ARRANGE LIKE PARTS TOGETHER AND AS CLOSE AS POSSIBLE TO WORKING AREA IN WHICH THEY ARE TO BE ASSEMBLED.
5. TOOL REQUIRED IS A 3/8" SOCKET WRENCH TO TIGHTEN NUTS.
6. READ REMAINDER OF THESE INSTRUCTIONS CAREFULLY BEFORE YOU PROCEED FURTHER AND FAMILIARIZE YOURSELF WITH ALL COMPONENTS NAMES.
7. NOW FOLLOW THE INSTRUCTIONS STEP BY STEP. A PAIR OF SAW HORSES WILL MAKE ASSEMBLY EASIER.
8. AFTER CABINET HAS BEEN PLACED IN ITS FINAL POSITION, IT MAY BE NECESSARY TO PLACE SHIMS UNDER CABINET TO OBTAIN PROPER DOOR ALIGNMENT.

**ASSEMBLY INSTRUCTIONS
FOR E-Z BILT CABINETS**



PENCO PRODUCTS, INC.
OAKS, PENNSYLVANIA

1-877-952-0151

REV. 5/87

PART NO. 08760

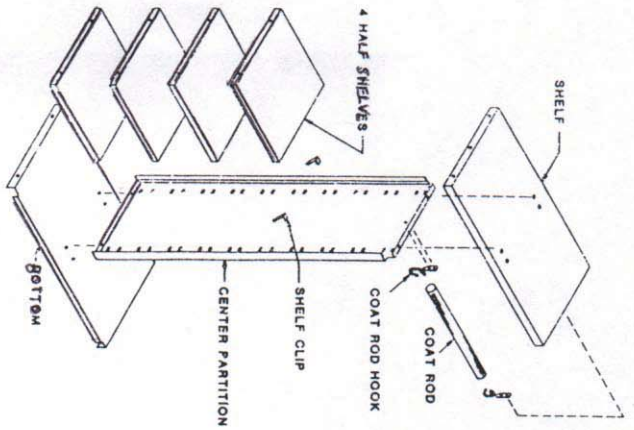

COMBINATION CONVERSION
FIGURE 5

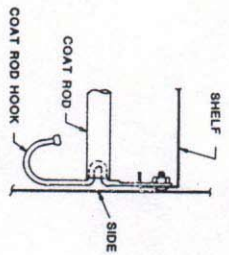

FIGURE 4

STORAGE CABINET ASSEMBLY

- 3.1 FOLLOW STEPS 1 & 2 ON PAGE 1.
- 3.2 INSTALL THE FOUR SHELVES INTO THE CABINET BY RAISING ONE END OF THE SHELF. PLACE THE SHELF INTO THE CABINET, HOOK THE LOW END INTO SIDE ADJUSTMENT STRIP AT DESIRED HEIGHT, AND LOWER SHELF INTO THE SAME HEIGHT HOOKS ON THE OPPOSITE SIDE. CHECK TO BE SURE THE SHELF IS LEVEL AND FULLY ENGAGED IN ALL FOUR HOOKS. REPEAT FOR THE REMAINING THREE SHELVES.

WARDROBE CABINET ASSEMBLY

- 4.1 FOLLOW STEPS 1 & 2 ON PAGE 1.
- 4.2 INSERT THE COAT HOOK THROUGH THE SLOT IN THE BOTTOM FLANGE AT THE SIDE OF THE SHELF. LINE UP HOLE, BOLT TOGETHER, AND TIGHTEN NUT. (FIG.4)
- 4.3 PUSH ONE END OF THE COAT ROD ONTO THE COAT HOOK, TAKE THE OTHER COAT HOOK, PUSH ONTO COAT ROD AND FASTEN TO SHELF
- 4.4 FOLLOW STEP 3.1 TO INSTALL SHELF INTO CABINET.

COMBINATION CABINET ASSEMBLY

- 5.1 FOLLOW STEPS 1 & 2 ON PAGE 1.
- 5.2 ATTACH A COAT HOOK ON THE RIGHT SIDE OF THE SHELF AS SHOWN IN FIG.5. INSTALL THE SHELF INTO THE CABINET 60" ABOVE THE BOTTOM.
- 5.3 BOLT IN THE CENTER PARTITION WITH 4 BOLTS USING THE HOLES TO THE LEFT SIDE OF THE SHELF AND BOTTOM.
- 5.4 PUSH THE OTHER COAT HOOK INTO THE COAT ROD ON THE LEFT HAND END OF ROD. THEN, PUSH THE RIGHT HAND END OF THE ROD ONTO THE COAT HOOK ATTACHED TO THE SHELF. POSITION LEFT HAND COAT HOOK AT THE CENTER OF PARTITION AND BOLT TO PARTITION USING 2 BOLTS.
- 5.5 INSTALL SHELF CLIPS IN PARTITION AT DESIRED LOCATIONS.
- 5.6 INSTALL HALF SHELVES INTO SIDE ADJUSTMENT STRIPS AT DESIRED LOCATIONS AND LOWER THE OTHER EDGE ONTO THE SHELF CLIPS ON THE PARTITION.
- 5.7 NOTE THAT THE PARTITION AND HALF SHELVES CAN BE USED ON EITHER SIDE. THE ABOVE DIRECTIONS ARE FOR LEFT HAND INSTALLATION. SIMPLY REVERSE THE DIRECTIONS FOR RIGHT HAND INSTALLATION.

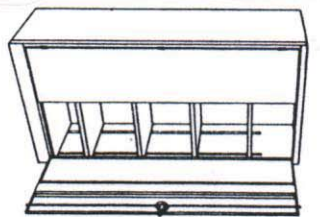
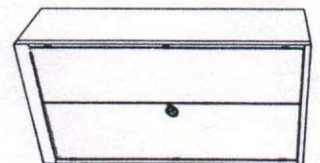

STORAGE

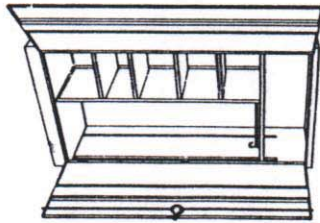
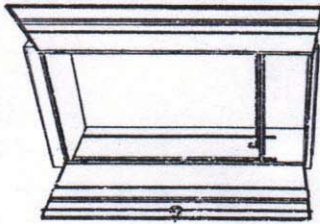

WARDROBE

COMBINATION

ASSEMBLY INSTRUCTIONS
FOR E-Z BILT CABINETS



PENCO PRODUCTS, INC.
OAKS, PENNSYLVANIA

SHT. NO. 2

PART NO. 08760

- ASSEMBLY INSTRUCTIONS FOR 78" HIGH STORAGE CABINET
- LAY DOWN TWO SPLIT HALF BACKS, KEEPING SHELF ADJUSTING STRIPS WITH THE TABS ON BOTH PIECES POINTING IN THE SAME DIRECTION AND BOLT THEM TOGETHER WITH #10 SCREWS AND NUTS.(FIG.1)
 - POSITION THE TOP SO THE REAR FLANGE IS OUTSIDE THE BACK AND BOLT IT TO THE BACK.(FIG.2)
 - TAKE RIGHT HAND CABINET SIDE, PLACE IT'S REAR FLANGE UNDER THE BACK AND TOP FLANGE OVER THE TOP, ALIGN HOLES AND BOLT IT TO BACK AND TOP.(FIG.1&FIG.2)
 - REPEAT STEP NO.3 FOR LEFT HAND CABINET SIDE.
 - SLIDE TOP CHANNEL OVER THE FRONT EDGE OF CABINET TOP. BOLT IT TO SIDES (1/4"-20 SCREWS) AND TOP.(FIG.2 & FIG.3).
 - BOLT THE BOTTOM CHANNEL TO THE SIDES WITH 1/4"-20 HARDWARE.(FIG.3)
 - PUSH THE CABINET BOTTOM ONTO THE TABS OF THE SHELF ADJUSTING STRIPS ON THE BACK (IF 48" WIDE) AND SIDES. DROP DOWN OVER THE TOP FLANGE OF THE BOTTOM CHANNEL. LINE UP THE HOLES AND BOLT IT TO THE BOTTOM CHANNEL.(FIG.4)
 - BOLT ANGLE SUPPORT TO THE BACK OF CABINET.
 - TAKE THE DOORS AND LINE UP HINGE SLOTS IN DOORS WITH HINGES (WELDED TO CABINET SIDE). BOLT DOORS TO THE HINGES. THE RIGHT HAND DOOR HAS A HOLE FOR THE HANDLE.(FIG.1)
 - SNAP NYLON BAR GUIDES INTO THE TOP AND BOTTOM FLANGES AND BOLT HANDLE AND CAM SPRING TO THE RIGHT HAND DOOR.(FIG.5)
 - REFER TO FIG.5, POSITION LOCK BARS BY PASSING THRU NYLON BAR GUIDES, AND HOLD OTHER ENDS TO CAM SPRING.
 - SLIP THE LATCH CAM OVER THE HANDLE SHAFT AND ENGAGE THE CAM LUGS IN THE LOCK BAR HOLES.(FIG.5)
 - COMPRESS THE CAM SPRING BY PUTTING PRESSURE ON LATCH CAM.(FIG.5)
 - PRESS PUSH ON FASTENER OVER THE HANDLE SHAFT.(FIG.5)
 - CAREFULLY STAND CABINET UPRIGHT.
 - INSTALL SHELVES BY RAISING ONE END OF THE SHELF. PLACE THE SHELF INTO THE CABINET ADJUSTING STRIP TABS, STARTING WITH THE BACK TABS, THEN REAR SIDE ADJUSTING STRIP TABS AND FINALLY DROP IT IN FRONT SIDE ADJUSTING STRIP TABS.
 - CHECK TO BE SURE THE SHELF IS LEVEL AND FULLY ENGAGED IN ALL SIX TABS.(SHELF ADJUSTING STRIP)
 - PLACE THE CABINET AT DESIRED LOCATION. IF FLOOR IS UNEVEN PLACE SHIMS UNDER CORNERS TO PREVENT THE DOORS FROM BINDING.

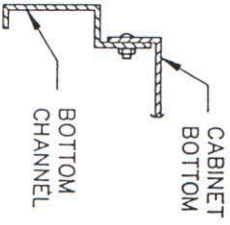

FIG.4

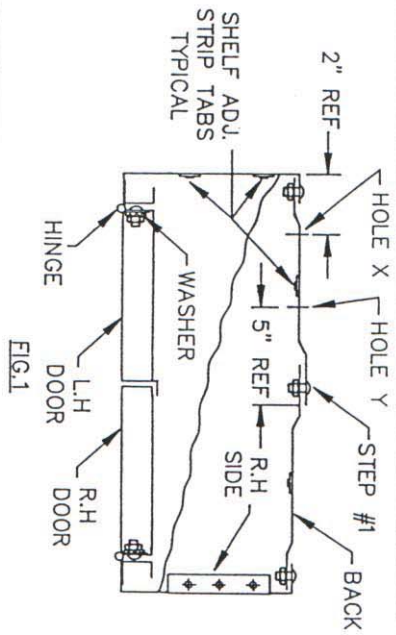

FIG.1

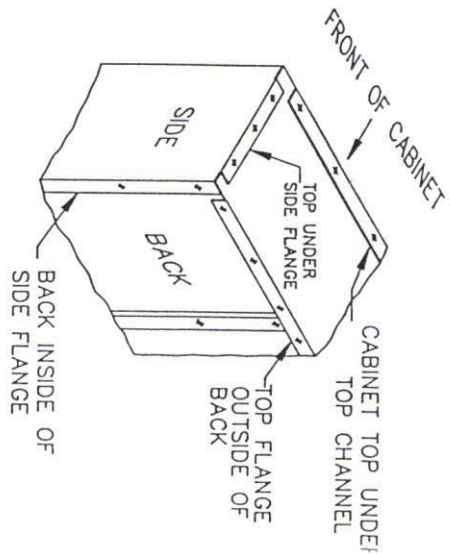

FIG.2

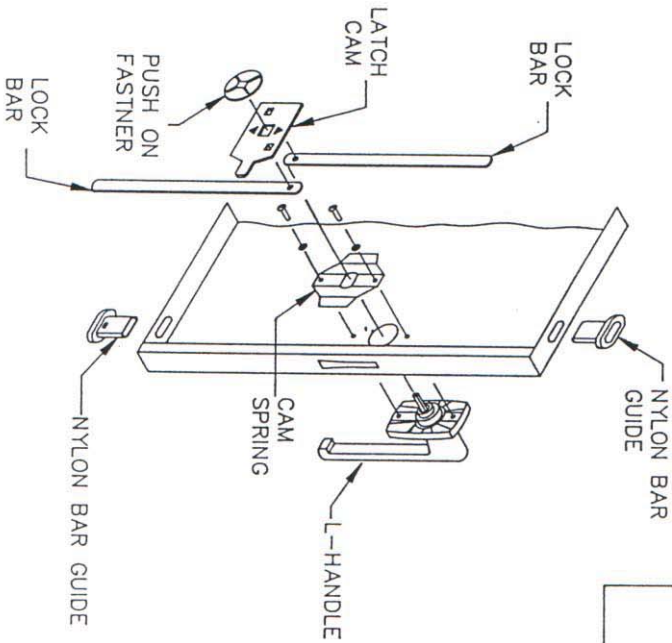

FIG.5

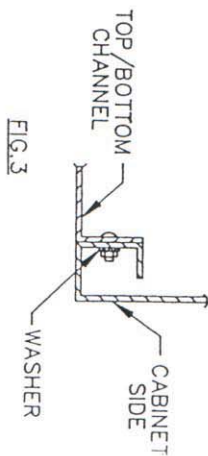

FIG.3

ASSEMBLY INSTRUCTIONS FOR SPLIT BACK STORAGE CABINET



PENCO PRODUCTS

OAKS, PENNSYLVANIA

PART NO. 08762

**ASSEMBLY INSTRUCTIONS FOR 42" HIGH
COUNTER UNIT STORAGE CABINET**

- 1 LAY DOWN TWO SPLIT HALF BACKS, KEEPING SHELF ADJUSTING STRIPS WITH THE TABS ON BOTH PIECES POINTING IN THE SAME DIRECTION (IF 48" WIDE) AND BOLT THEM TOGETHER WITH #10 SCREWS AND NUTS (FIG.1)
- NOTE: 36" WIDE CABINET BACKS DON'T HAVE SHELF ADJ. STRIPS. WHEN ASSEMBLING BACKS FOR 36" WIDE UNITS, BE CAREFUL TO POSITION HOLES "X" & "Y" IN THE LOCATIONS SHOWN (FIG.1) HOLES X & Y ARE LOCATED NEAR THE TOP AND BOTTOM EDGES OF BACK PCS. IF ASSEMBLED INCORRECTLY, HOLES AT THE TOP AND BOTTOM WILL NOT MATCH OTHER PCS.
- 2 TAKE RIGHT HAND CABINET SIDE, PLACE IT'S REAR FLANGE UNDER THE BACK. LINE UP HOLES AND BOLT IT TO THE BACK (FIG.1)
- 3 REPEAT STEP NO.2 FOR LEFT HAND CABINET SIDE.
- 4 POSITION THE CABINET TOP SO REAR FLANGE IS OUTSIDE THE BACK. BOLT IT TO THE BACK AND SIDE. {3 BOLTS EACH SIDE, 1 SHEET METAL SCREW EACH END AND 4 BOLTS (OR 6 IF 48" WIDE) ACROSS THE BACK} (FIG.6 & 7)
- 5 TO COMPLETE ASSEMBLY, FOLLOW STEPS #6 THRU #18 FROM "ASSY" INSTRUCTIONS FOR STORAGE CABINET".

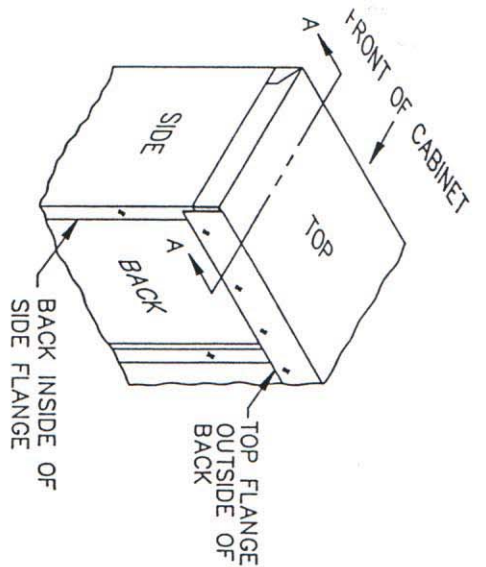
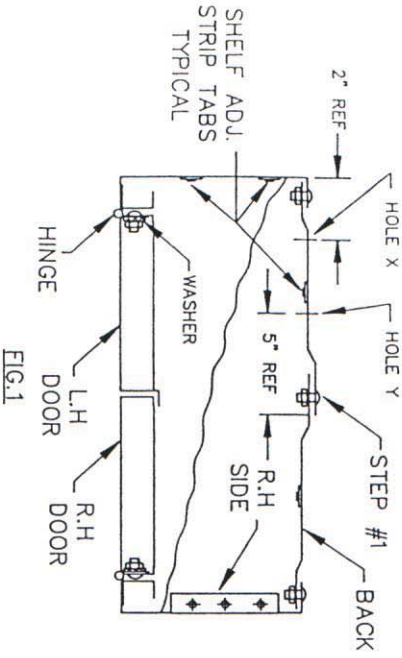

FIG.6

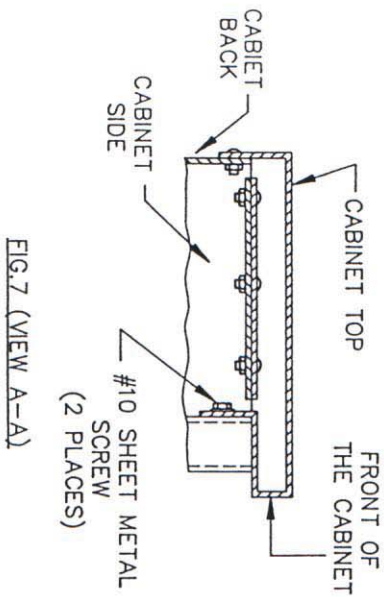

FIG.7 (VIEW A-A)

ASSEMBLY INSTRUCTIONS FOR
SPLIT BACK STORAGE CABINET