

SchoolLockers.com

Toll Free: 877-952-0151 • Fax: 801-493-0158

Your Locker Advantage!

• Email: lockers@schoollockers.com

ELECTRONIC LOCKS

RFID Locker Lock Systems #2154, #2254



#2254 (front view)



#'s 2154 & 2254 (rear view)

DIMENSIONS

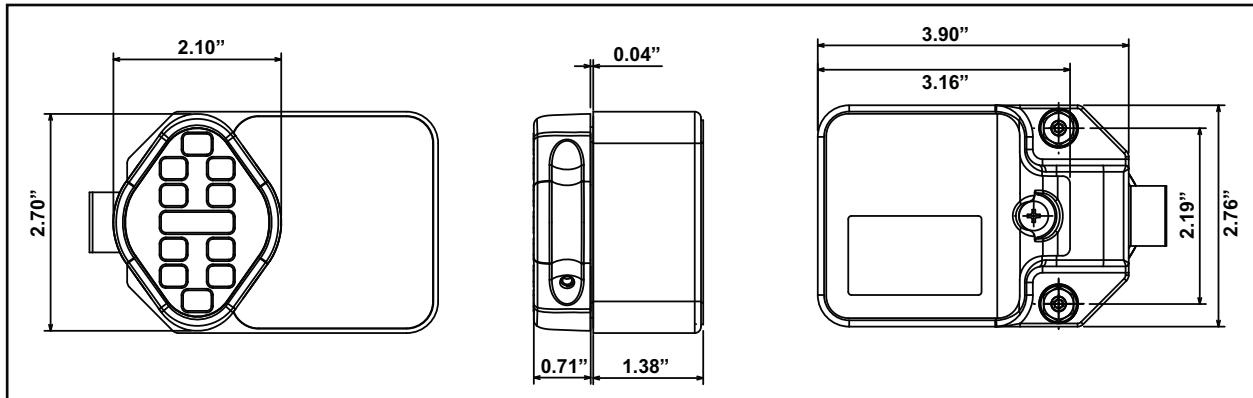

FEATURES

- Unique card key with same security level as used in Banking Smart Cards
- Complies with all ADA guidelines for ADA accessibility
- Engineered to work on all standard metal single point, box locker, gravity latch/multipoint lockers, wood & laminate lockers and casework
- Supervisory override card capability
- Programmable for both day use and permanent use
- Custom programmability available
- High impact polycarbonate housing
- Ability to track user history
- New user cards available in the event card is lost
- Battery Powered; Requires (4) AA batteries offering life cycle of 10,000 - 20,000 uses depending on model
- All RFID models have a 1 year warranty from the time of shipment

APPLICATIONS

- Athletic, student & swimming facility lockers
- OEM equipment
- Health & fitness clubs, day spas, wellness centers
- Employee lockers
- Golf & country clubs, hotels, resort lockers
- Evidence lockers

Model 2154
installed on
wood locker door

